

SMART 180 D/280 D



MOTORIZATION

**Nr 1 Collector
motor**

MATERIAL TO VACUUM

Dust

FILTER TYPE

Cartridge

FILTER CLEANING

**Semi-Automatic -
Button**

The SMART series vacuum cleaners and in particular the SMART 180D and SMART 280D models are dedicated to professionals in various sectors who need a compact vacuum cleaner, robust and effective in extracting even the finest dust. These vacuums have filtering capacities above their category and an integrated filter cleaning system, proving to be the best alternative to classic professional vacuums. TOOL versions available, with electrical socket on the head and remote ignition via Powertools MAX 16 A.

Features



COLLECTION TANK
Fast emptying



NEW HEAD
New and improved head

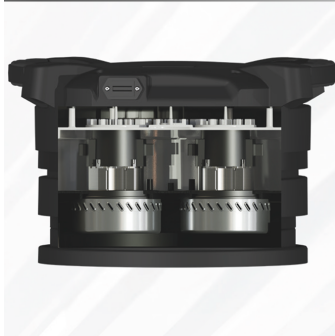

BY-PASS MOTORS
Efficient By-pass motors



POWERTOOLS
Powertool available

Technical specifications

Technical data	SMART 180 MD.	SMART 180 HD	SMART 280 MD	SMART 280 HD
MATERIAL TO VACUUM	Dust	Dust	Dust	Dust
MOTORIZATION	Nr 1 Collector motor	Nr 1 Collector motor	Nr 2 Collector motor	Nr 2 Collector motor
MARKING	-	-	-	-
POWER	1100 W	1100 W	2200 W	2200 W
VOLTAGE	230 V	230 V	230 V	230 V
FREQUENCY	50 / 60 Hz	50 / 60 Hz	50 / 60 Hz	50 / 60 Hz
AMPERAGE	4,8 A	4,8 A	9,6 A	9,6 A
AIR CONSUMPTION	-	-	-	-
AIRFLOW	170 m3/h	170 m3/h	340 m3/h	340 m3/h
DEPRESSION	230 mBar	230 mBar	230 mBar	230 mBar
MAX DEPRESSION	-	-	-	-
SUCTION INLET	Type A Tang. 60 mm	Type A Tang. 60 mm	Type A Tang. 60 mm	Type A Tang. 60 mm
DIMENSIONS	43x48 h92 cm	43x48 h92 cm	43x48 h92 cm	43x48 h92 cm
WEIGHT	23	23	23	23
COLLECTION SYSTEM	Barrel	Barrel	Barrel	Barrel
COLLECTION CAPACITY	25 L	25 L	25 L	25 L
LONGOPAC	-	-	-	-
ELECTRIC FLOATER	-	-	-	-
FILTER CHAMBER DIAMETER	Ø 370mm	Ø 370mm	Ø 370mm	Ø 370mm
FILTER TYPE	Cartridge	Cartridge	Cartridge	Cartridge
FILTERING MEDIA AND PROPERTIES	M Conductive Aluminized	HEPA + PTFE	M Conductive Aluminized	HEPA + PTFE
FILTER SURFACE	9.000 cm2	9.000 cm2	9.000 cm2	9.000 cm2
FILTER CLEANING	Semi-Automatic - Button	Semi-Automatic - Button	Semi-Automatic - Button	Semi-Automatic - Button
LIQUID EMPTYING	-	-	-	-
FILTER HEPA	-	-	-	-
HEPA FILTERING SURFACE	-	-	-	-

Accessories

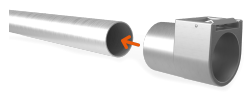

QUICK COUPLING
SLEEVE FOR
ACCESSORIES - Ø 50
MM. - 200270

200270

Quick coupling sleeve for
accessories - Ø 50 mm.